

AMERICAN RANGE

Quality Commercial Cooking Equipment

www.americanrange.com

AECEB HEAVY DUTY CHAR ROCK BROILER

The American Range heavy duty Char Rock Broiler is designed to provide reliable, solid performance for many years. Self-cleaning, long lasting, natural volcanic char rock is used to give the authentic effect and true flavor of Char Broiling. The juices from the meat drip down onto the rocks, resulting in searing flames and smoke that enhances flavor.

Innovative design features heavy duty cast iron top grates which are pitched with a cast in grease trough in each blade for fat run off; this minimizes "flare-up".

Individually controlled 35,000 BTU/hr burners are located every nine inches designed to provide complete coverage of a large cooking area, while providing flexibility to operate chosen burners as needed, thus saving energy.

All our quality counter appliances come standard with a stainless steel exterior and the best warranty in the business. Look to American Range for innovation, reliable performance, quality and attention to your equipment needs and delivery, now and in the future.



SHOWN WITH OPTIONAL STAINLESS STEEL LANDING LEDGE



AECEB

STANDARD FEATURES

- Individually controlled cast Iron "H" burners placed every 9".
- Providing maximum output, even heat distribution, flexibility and low maintenance.
- Manual gas control valve for each burner.
- Standing pilots for instant ignition for each burner.
- Sectioned top grates individually removable for easy cleaning.
- Heavy Duty cast iron top grates are angled to control "Flare-up".
- 14 GA. all welded heavy duty reinforced fire box.
- Stainless steel polished front and trim for easy cleaning, with fully insulated double layered steel chassis.
- Full length grease trough drains the run off into a removable pan for easy cleaning.



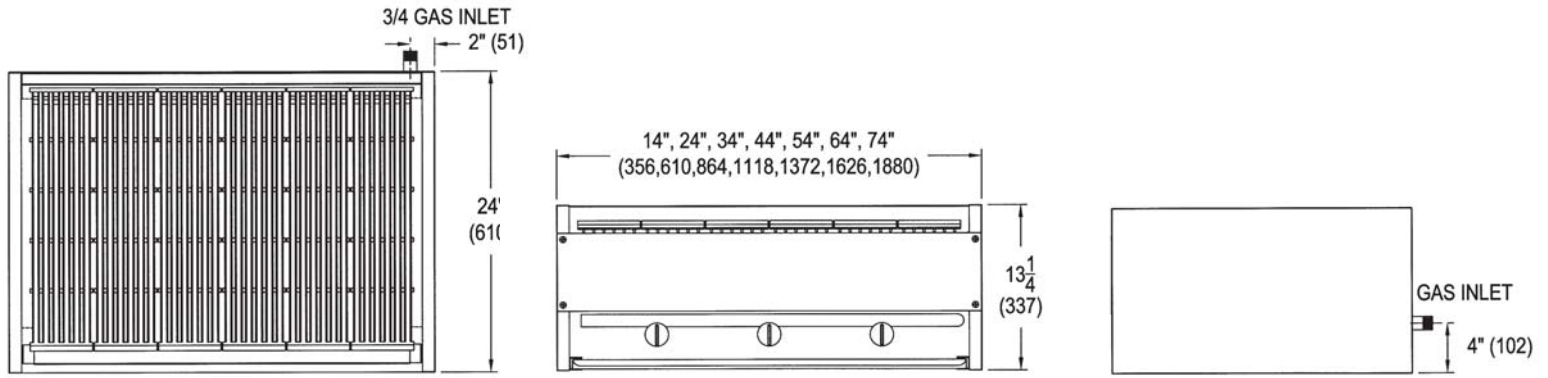

HEAVY DUTY CHAR ROCK BROILER

MODEL	WIDTH	DEPTH	HEIGHT	BURNERS	TOTAL BTU	KW	SHIP. WT. Lbs.	Kg.
AECB-14	14"	24"	13" 1/4	1	35,000	10.26	90	41
AECB-24	24"	24"	13" 1/4	2	70,000	20.51	165	75
AECB-34	34"	24"	13" 1/4	3	105,000	30.77	240	109
AECB-44	44"	24"	13" 1/4	4	140,000	30.77	315	143
AECB-54	54"	24"	13" 1/4	5	175,000	41.03	390	176
AECB-64	64"	24"	13" 1/4	6	210,000	61.54	465	210
AECB-74	74"	24"	13" 1/4	7	245,000	71.80	540	244
AECB-84	84"	24"	13" 1/4	8	280,000	82.00	615	278

SALIENT FEATURES

- True Charbroiled flavor with natural volcanic char rock. Juices drip onto the rocks resulting in searing flames and smoke that enhance the flavor of the food.
- Individually controlled cast iron "H" shaped burners, 35,000 BTU/hr. spaced for even heat distribution.
- Heavy duty cast iron top grates, 5" (127) x 21" (533), reversible, with grease runners to direct the run off to the removable grease trough. Provides markings on the food. Top grates can be positioned flat or sloped.
- AGA and CGA design certified. NSF listed.

AVAILABLE OPTIONS

- S/S Landing ledge available in 6" (152), 8" (203), 10" (254) depth.

Gas: Manifold pressure is 5.0" W.C. for natural gas or 10.0" W.C. for propane gas. Manifold size: 3/4" (19) NPT. Specify type of gas and altitude if over 2000 feet.

Clearances: For use in non combustible locations only, Clearance to non combustible construction 0".

American Range Corporation is a quality manufacturer of commercial cooking equipment. Because of continuing product improvements these specifications are subject to change without prior notice.

