

AMERICAN RANGE

Quality Commercial Cooking Equipment

www.americanrange.com

AM5Q HEAVY DUTY MESQUITE WOOD BROILER

American Range provides as standard many of the optional upgrades normally offered at a premium on other Mesquite Wood Broiler lines. The new look features a stainless steel front and sides. Located on the front of the broiler is a large chute for easy loading and moving of wood and charcoal during operation. A built-in gas log lighter eliminates the need for messy lighter fluids or electric starters and can be used during "peak" periods. The American Range Mesquite Wood Broiler enhances the flavor of meat, fish and poultry with the unique flavor of mesquite. The broiler makes mesquite broiling convenient and efficient. The unique open grate bottom allows a continuous updraft of air for optimal fuel combustion saving wood and charcoal costs. The heavy duty cast iron grates make attractive broiling marks to add appetite appeal.



SHOWN WITH
OPTIONAL STAND
AND CASTERS

NSF

AM5Q



STANDARD FEATURES

- Stainless steel front and sides.
- Built-in gas log lighter burner eliminates the need for lighter fluids or electric starters.
- Burner may be used to start up wood, or when adding more wood during "peak" operating times.
- Broiler may use any type of wood or charcoal.
- Unique design incorporates an open-grate bottom that allows a continuous updraft of air to optimize fuel combustion and save wood and charcoal costs.
- Burners are equipped with continuous pilots for instant ignition.
- 6" x 24" cast iron top grates give attractive broiling markings.
- Must have optional stand or legs ordered.

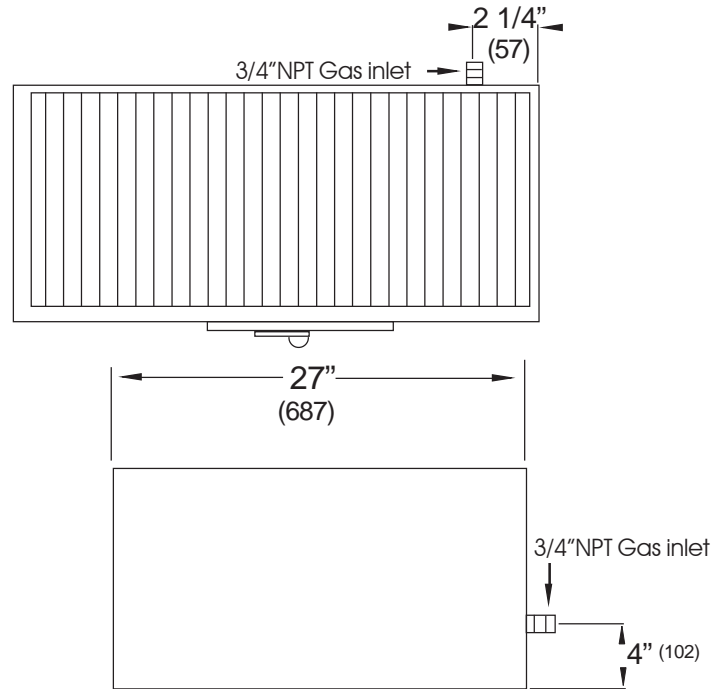
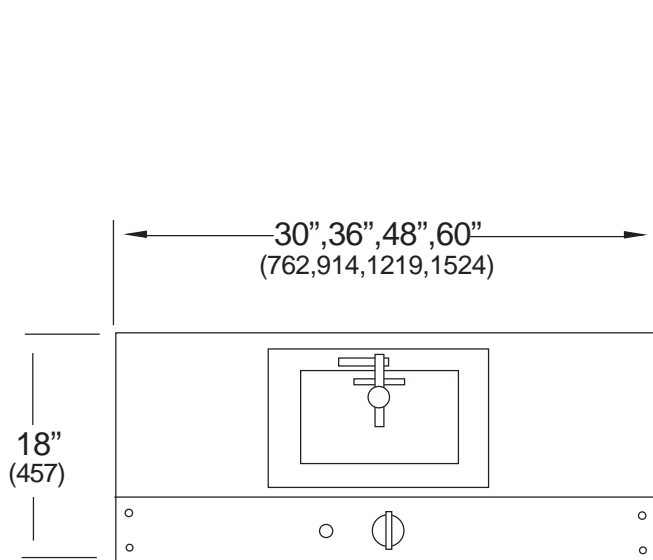

MESQUITE BROILER

MODEL	WIDTH	DEPTH	HEIGHT	BURNERS	TOTAL BTU	KW	OPTIONAL STAND	SHIP. WT. Lbs.	Kg.
AMSQ-30	30"	27"	18"	1	20,000	5.86	MSQS-30	300	137
AMSQ-36	36"	27"	18"	1	20,000	5.86	MSQS-36	345	157
AMSQ-48	48"	27"	18"	1	20,000	5.86	MSQS-48	405	184
AMSQ-60	60"	27"	18"	2	40,000	11.72	MSQS-60	455	210

FEATURES

- Heavy duty all stainless steel exterior.
- Durable chrome plated control knob.
- Large stainless steel door with chute located on the front of the broiler allows easy loading and moving of wood and charcoal during operation.
- Must have optional MSQS stand or 4" (102) legs.

OPTIONS

- Top grate made from 1/2" (12) round steel rod, welded for durability.
- Optional open top stand.
- 4" (102) counter legs.
- Quick disconnect and flexible gas hose.

BROILERS

- Burners are built-in gas log lighter with adjustable gas valve and standing pilot for instant ignition.
- Heavy duty cast iron section grates for attractive markings on food.
- Bottom grate: Open bottom grate allows continuous updraft for optional fuel combustion.
- Drip Pan: Removable deep drip pan at the bottom for convenient cleaning of ash and debris.
- Cleaning: Easy cleaning of all grates and inner liner, no tools required.
- Removable Liner: Heavy duty liner protects the interior from burn out and is easy to replace when needed.

Gas: Manifold pressure is 5.0" W.C. for natural gas or 10.0" W.C. for propane gas. Specify type of gas and altitude if over 2000 feet.
3/4" NPT Gas Inlet.

Clearances: For use in non combustible locations only, Clearance to non combustible construction 0".

American Range Corporation is a quality manufacturer of commercial cooking equipment. Because of continuing product improvements these specifications are subject to change without prior notice.

