

AMERICAN RANGE

Quality Commercial Cooking Equipment

www.americanrange.com

ARKB

ARKB HEAVY DUTY KEBOB BROILERS

The American Range heavy duty Kebob Broiler is designed to provide reliable, solid performance for many years. This Broiler allows juices from the meat to drip down onto the radiants, resulting in searing flames and smoke flavor. Innovative design features heavy gauge steel support bars specially spaced to allow sure support of the "shish" skewers. Individually controlled 30,000 BTU/hr burners located every six inches is designed to provide complete coverage of a large cooking area. Providing flexibility to operate chosen burners as needed thus saving energy. All our quality counter appliances come standard with a stainless steel exterior and the best warranty in the business. Look to American Range for innovation, reliable performance, quality and attention to your equipment needs and delivery, now and in the future.



ARKB

STANDARD FEATURES

- Individually controlled Stainless Steel 30,000 BTU/hr burners placed every 6",
- providing maximum output, flexibility and low maintenance.
- Manual gas control valve for each burner, allows use of selected burners.
- Heavy Duty radiant bars for optimum heat distribution.
- Radiant Bars individually removable for easy cleaning.
- Heavy Gauge supports are spaced to hold skewers.
- 14 GA all welded Heavy Duty reinforced fire box.
- Stainless Steel polished front and trim for easy cleaning, with
- fully insulated double layered all welded steel chassis.
- Full length removable crumb tray for easy cleaning.
- Optional 4" legs or equipment stand available.
- AGA and CGA design certified, NSF Listed.



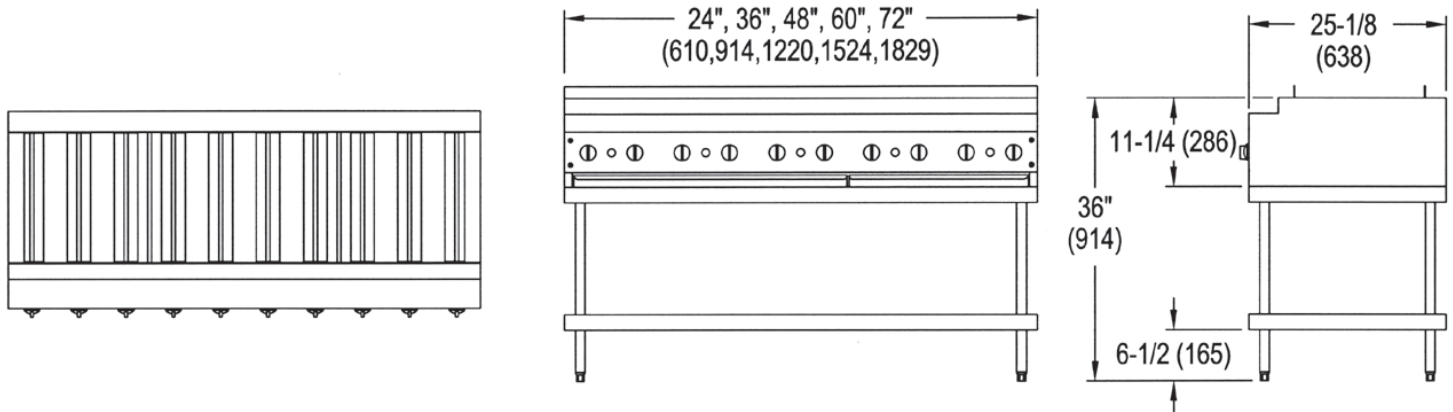

HEAVY DUTY KEBOB BROILER

MODEL	WIDTH	DEPTH	HEIGHT	BURNERS	TOTAL BTU	KW	SHIP. WT. Lbs.	Kg.
ARKB-24	24"	25 1/8"	11 1/4"	4	120,000	35.16	325	147
ARKB-30	30"	25 1/8"	11 1/4"	5	150,000	43.96	350	150
ARKB-36	36"	25 1/8"	11 1/4"	6	180,000	52.75	395	179
ARKB-48	48"	25 1/8"	11 1/4"	8	240,000	70.34	490	222
ARKB-60	60"	25 1/8"	11 1/4"	10	300,000	87.92	550	249
ARKB-72	72"	25 1/8"	11 1/4"	12	360,000	105.5	610	276

STANDARD FEATURES

- Individually controlled Stainless Steel 30,000 BTU burners placed every 6", (152) providing maximum output, flexibility and low maintenance.
- Manual gas control valve for each burner, allows use of selected burners.
- Heavy Duty radiant bars for optimum heat distribution.
- Radiant Bars individually removable for easy cleaning.
- Heavy Gauge supports are spaced to hold skewers.
- 14 GA all welded Heavy Duty reinforced fire box.
- Stainless Steel polished front and trim for easy cleaning with fully insulated double layered all welded steel chassis.
- Full length removable crumb tray for easy cleaning.
- AGA and CGA design certified, NSF Listed.
- One Year Limited Warranty, parts and labor.

OPTIONS

- Rotisserie Available.
- S/S equipment stand.
- Sectional top grates.
- Quick disconnect.
- S/S shish kebob skewers.
- S/S cover.

Gas: Manifold pressure is 5.0" W.C. for natural gas or 10.0" W.C. for propane gas. Specify type of gas and altitude if over 2000 feet. 3/4" NPT Gas inlet.

Clearances: For use in non combustible locations only, Clearance to non combustible construction 0" sides and rear.

American Range Corporation is a quality manufacturer of commercial cooking equipment. Because of continuing product improvements these specifications are subject to change without prior notice.

