



COUNTERTOP FRYER

WITH INTERLOCK DRAIN VALVE 15LB / 30LB

COUNTERTOP FRYER



Drain Valve

“Anvils deep fat fryers are designed to create a delicious variety of crisp fried food with minimum fuss. Delight your customers with french fries, chicken, fish, seafood, etc.”

APPLICATION

- IDEAL FOR USE IN RESTAURANTS, TAKE AWAYS, CANTEENS, ETC.
- SUITABLE FOR FROZEN PRODUCTS WITH EXCELLENT RECOVERY TIME

CONSTRUCTION

- LIFT-OUT ELEMENT BOX FOR EASY CLEANING
- FITS INTO TIGHT COUNTER SPACES
- PILOT LIGHT INDICATES POWER ON
- FITTED WITH SAFETY INTERLOCKED DRAINAGE VALVE

HEATING

- VARIABLE HEAT CONTROL FROM 122°F - 374°F
- REACHES FRYING TEMPERATURES FAST
- RECOVERS TO OPERATING TEMPERATURE QUICKLY BETWEEN LOADS

ACCESSORIES

- NICKEL-PLATED MILD STEEL WIRE BASKET

SAFETY FEATURES

- AUTOMATIC CUT-OUT AT 390°F TO PREVENT OIL FIRE

Anvil reserves the right, without notice, to make changes and revisions to product specifications, materials and design, which in our opinion, will provide better performance, durability and efficiency.



ALL ANVIL EQUIPMENT COMES WITH A ONE YEAR WARRANTY ON COMPONENTS AND DEFECTIVE WORKMANSHIP



ANVIL



COUNTERTOP FRYER

MODELS:
FFA8115
FFA8130

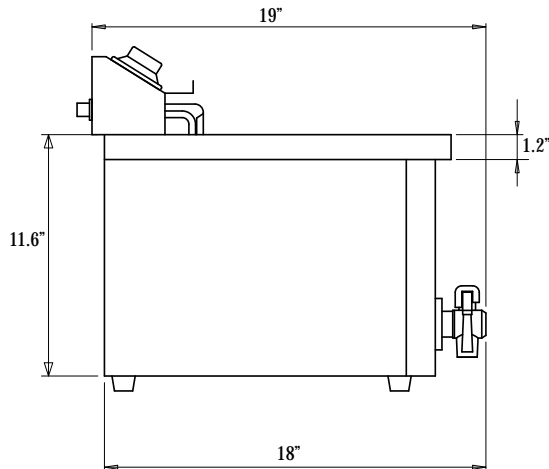
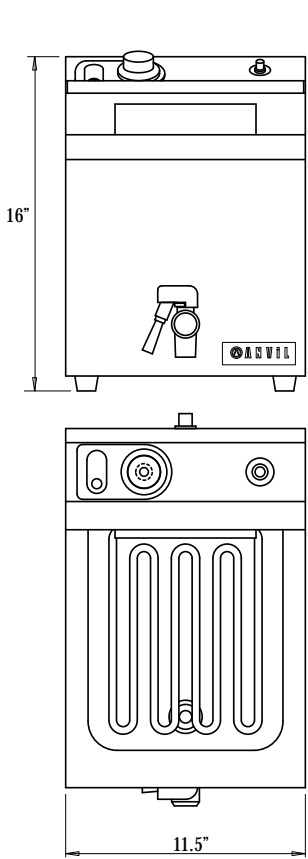

NOTE:

When viewing the appliance from the front in its usual operating position, the width (W) of the product is the total distance from left to right ; the depth (D) of the product is the total distance from front to back ; the height (H) is the total distance from the bottom of the product to the top

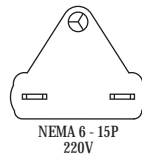

NEMA 6 - 15P
220V

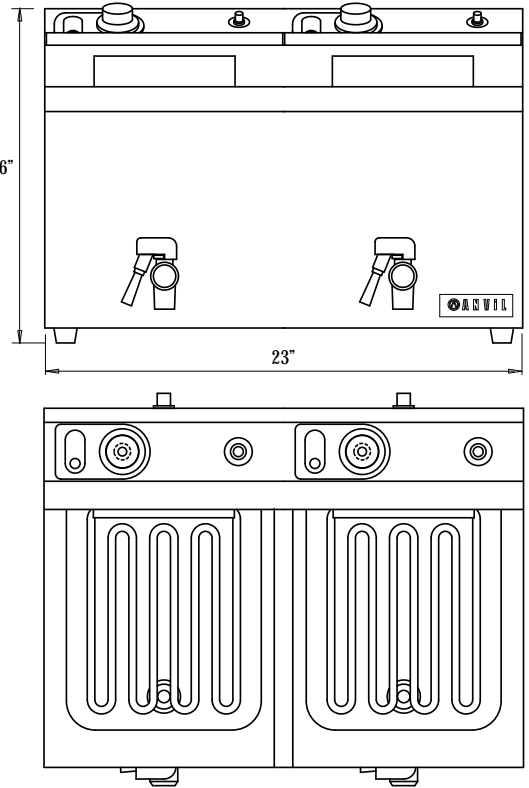

DESCRIPTION	FRYER 15lb	FRYER 30lb
MODEL	FFA8115	FFA8130
VOL. OF OIL (lbs)	15	30
± FRENCH FRIES (lbs/hr)	30	60
VOLTAGE (V)	220	220
POWER (Kw)	3.0	6.0
DIMENSIONS (in) (W x D x H)	11.5 x 18 x 16	23 x 18 x 16
BOX DIMNS (in) (W x D x H)	12 x 23 x 17.5	23.5 x 23x 17.5
PACKED WEIGHT (lbs)	25	42

Note: Output performance figures quoted are dependant on various factors.

Website: www.anvilworld.com

